

# BY-PASS 3000 The Original



## DC fuel transfer pump

Displacement, self-priming, rotary electric vane pumps for the transfer of diesel fuel equipped with by-pass valve.

Powerful, dependable and economical, they are available with 12 and 24-volt direct current motors.

Thanks to their compact size, ease of installation, dependability and safety, these pumps are used as the primary system on earth-moving machinery and on mobile fuel pumps on vehicles or in construction yards.

## Technical Specifications

- Cast iron pump body finished with anti-corrosion paint.
- Vane pump with sintered steel rotor and acetal resin vanes.
- By-pass valve incorporated in the pump body.
- Direct current brush motor with permanent magnet stator.
- Motor protection grade IP55.
- Used in intermittent service with 30-minute work cycles.
- Pump attachment support bracket.

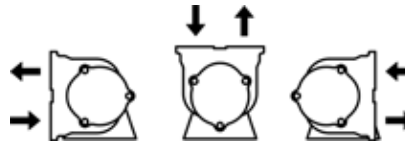
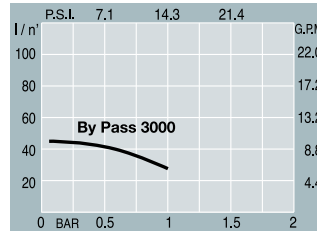

Flow rate up to **50** l/min

12 Volt working

24/12 Volt working

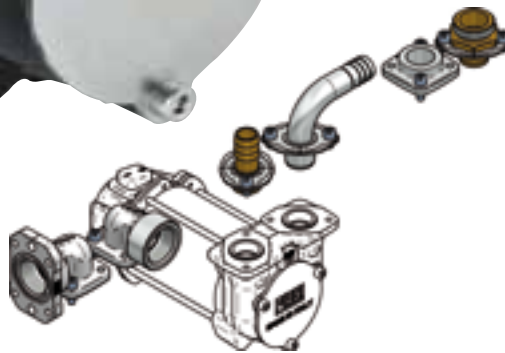

## Choose your best connections

Kit straight hose tail 3/4"  
Code F16172000  
(No.02 pcs)



90° hose tail 3/4"  
Code F16173000  
(No.01 pcs)



Flanged elbow 1" BSP  
Code F16178000  
(No.01 pcs)



Flanged elbow 1" BSP  
Code F16770000  
(No.01 pcs)



## On request



• KIT terminal box + 2mt cable + fuse 25A with clamp BP3000 12V  
Code F16293000

• KIT terminal box + 4mt cable + fuse 25A with clamp BP3000 12V  
Code F16295000

• KIT terminal box + 2mt cable + fuse 15A with clamp BP3000 24V  
Code F16294000

• KIT terminal box + 4mt cable + fuse 15A with clamp BP3000 24V  
Code F16296000

Terminal box  
Code  
F1601100A







## Available:

### CARRY3000



With cable length 2 m



Code	Description	Flow rate		DC				Max working pressure bar	Fuse Amp	Weight Kg	Packaging mm
		l/min	gal/min	Volt	rpm	Amp	Duty cycle min				
F00342000	BP3000 12V 	50	13	12	2900	22	30	1,5	-	3,5	200x350x270
F00347000	BP3000 24V / 12V 	50/30	13/6	24/12	2900/1500	11/6	30	1,5	-	3,5	200x350x270
F0022300C	Carry 3000 12V 	50	13	12	2900	22	30	1,5	25	4,2	215x120x160
F0022400C	Carry 3000 24V / 12V 	50/30	13/6	24/12	2900/1500	11/6	30	1,5	15	4,2	215x120x160

## IT Pompe per travaso

Elettropompe del tipo rotativo volumetrico autoadescante a palette per il travaso di gasolio, dotata di valvola By-Pass. Potenti, affidabili ed economiche sono disponibili con motore a corrente continua 12 e 24 Volt. Grazie alla compattezza, facilità d'installazione, affidabilità e sicurezza, queste pompe trovano impiego come primo impianto su macchine movimento terra e per equipaggiare distributori mobili su veicoli o da cantiere.

### Caratteristiche tecniche

- Struttura del corpo pompa in ghisa con trattamento anticorrosione e verniciatura di finitura.
- Pompa del tipo a palette con rotore sinterizzato e palette in resina acetale.
- Valvola by pass incorporata nel corpo pompa.
- Motore a corrente continua, a spazzole con statore a magneti permanenti.
- Protezione motore IP55.
- Utilizzo in servizio intermittente con ciclo di lavoro di 30 min.
- Staffa di supporto per fissaggio pompa.

## FR Pompes pour transvasement

Electropompes du type rotatif volumétrique à amorçage automatique à palettes pour le transvasement du gasoil, équipées avec soupape by-pass. Puissantes, fiables et économiques, elles sont disponibles avec moteur à courant continu 12 et 24 Volt. Grâce à leur compacité, à leur facilité d'installation, leur fiabilité et sécurité, ces pompes sont employées comme première installation sur des machines de terrassement et pour équiper les distributeurs mobiles sur véhicules ou sur chantier.

### Caractéristiques techniques

- Structure du corps de la pompe en fonte avec traitement anti-corrosion et peinture de finition.
- Pompe du type à palettes avec rotor fritté et palettes en résine acétale.
- Soupape by-pass incorporée dans le corps de la pompe.
- Moteur à courant continu à brosses avec stator à aimants permanents.
- Protection moteur IP55.
- Utilisation en service intermittent avec cycle de travail de 30 minutes.
- Etrier de support pour la fixation de la pompe.

## DE Pumpen zum Umfüllen

Selbstansaugende Flügelzellenverdrängerpumpen zum Umfüllen von Dieseldieselkraftstoff mit Bypass-Ventil. Sie sind leistungsstark, zuverlässig, wirtschaftlich und auch mit 12- und 24-Volt Gs-Motor erhältlich. Dank ihrer Kompaktheit, leichten Installation, Zuverlässigkeit und Sicherheit dienen diese Pumpen als Erstausrüstung von Bodenbearbeitungsmaschinen und zur Ausrüstung von Tankstellen, die fahrbar sind oder auf Baustellen stehen.

### Technische Merkmale

- Pumpenkörperstruktur aus Gußeisen mit Rostschutzbehandlung und Deckanstrich.
- Flügelpumpe mit gesintertem Rotor und Flügeln aus Acetalharz.
- Im Pumpenkörper eingebautes Bypass-Ventil.
- Gs-Bürstenmotor mit Stator mit permanenten Magneten.
- Schutzklasse IP55.
- Für Aussetzbetrieb mit 30-Minuten-Arbeitszyklus.
- Haltebügel zum Befestigen der Pumpe.

## ES Bombas para transvase

Electrobombas de tipo rotatorio volumétrico autocebante de paletas para el transvase de gasóleo, dotadas de válvula By-Pass. Potentes, fiables y económicas están disponibles con motor de corriente continua de 12 y 24 Volts. Gracias a su solidez, facilidad de montaje, fiabilidad y seguridad, estas bombas se emplean en primer lugar en máquinas para mover tierra y también para equipar distribuidores móviles en vehículos u obras.

### Características técnicas

- Estructura del cuerpo de la bomba en hierro fundido con tratamiento anticorrosión y barnizado de acabado.
- Bomba de paletas con rotor de acero sinterizado y paletas de resina acetálica.
- Válvula by-pass incorporada en el cuerpo de la bomba.
- Motor de corriente continua, de cepillos con estator de imanes permanentes.
- Protección motor IP55.
- Funcionamiento intermitente con ciclo de trabajo de 30 min.
- Chapa de soporte para la fijación de la bomba.

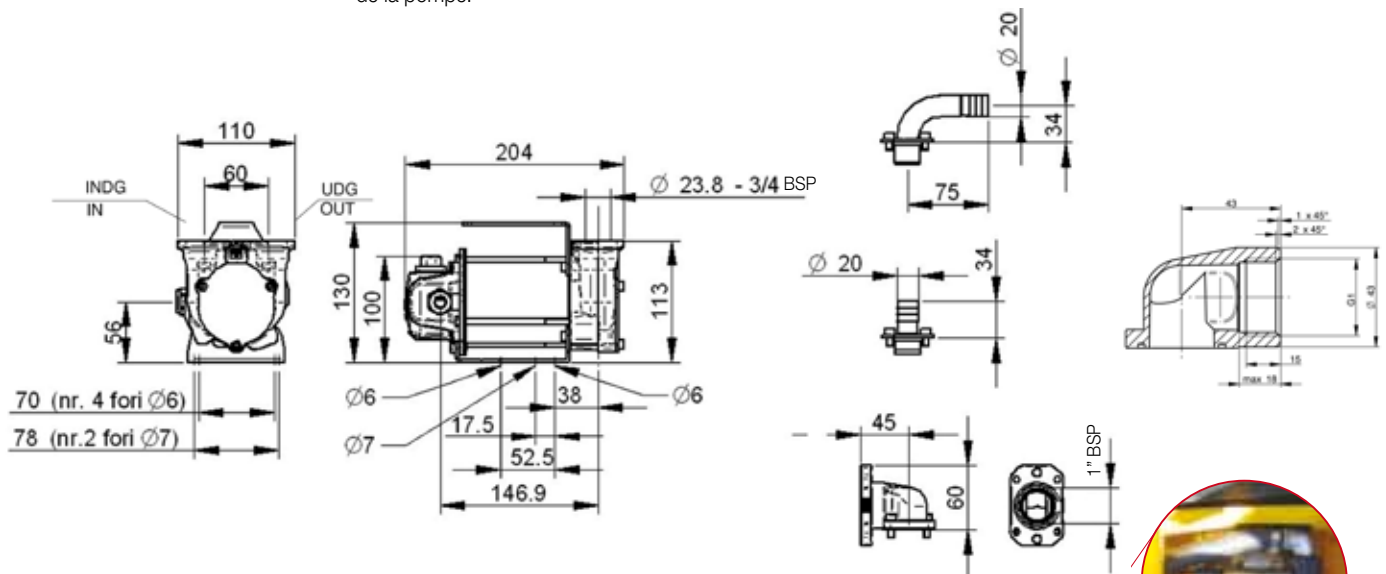

The Company reserves the right to modify the information contained in this catalogue without any prior notice.

**PIUSI**  
®

Certified  
ISO 9001 / ISO 14001

**PIUSI S.p.A.**  
46029 Suzzara (Mantova) ITALY  
Tel. +39-0376.534561  
Fax: +39-0376.536393  
e-mail: piusi@piusi.com  
www.piusi.com

**PIUSI USA, Inc.**  
2365 SW 34th St.  
FORT LAUDERDALE, FL 33312, USA  
Tel. : +1 954 584 1552  
Fax.: +1 954 584 1554  
e-mail: piusiusa@piusiusa.com  
www.piusiusa.com

  
Since 1953